

Highly Integrated Green-Mode PWM Controller

SG6742

FEATURES

- High-voltage start-up
- Low operating current (4mA)
- Linearly decreasing PWM frequency to 22KHz
- Frequency jittering to reduce EMI emission
- Fixed PWM frequency (65KHz)
- Peak-current-mode control
- Cycle-by-cycle current limiting
- Leading-edge blanking
- Synchronized slope compensation
- Internal open-loop protection
- GATE output maximum voltage clamp (18V)
- V_{DD} under-voltage lockout (UVLO)
- V_{DD} over voltage protection (OVP)
- Programmable over-temperature protection (RT)
- Internal latch circuit (OVP, RT)
- Constant power limit (full AC input range)
- Internal OTP sensor with hysteresis

APPLICATIONS

General-purpose switch-mode power supplies and flyback power converters, including:

- Power Adapters
- Open-Frame SMPS

DESCRIPTION

The highly integrated SG6742 series of PWM controllers provides several features to enhance the performance of flyback converters.

To minimize standby power consumption, a proprietary green-mode function provides off-time modulation to linearly decrease the switching frequency at light-load conditions. To avoid acoustic noise problems, the minimum PWM frequency is set above 22KHz. This green-mode function enables the power supply to meet international power conservation requirements. With the internal high-voltage start-up circuitry, the power loss due to bleeding resistors is eliminated. To further reduce power consumption, SG6742 is manufactured using the BiCMOS process, which allows an operating current of 4mA.

SG6742 integrates a frequency hopping function that helps reduce EMI emission of a power supply with minimum line filters. Also, its built-in synchronized slope compensation achieves stable peak-current-mode control. The proprietary internal line compensation ensures constant output power limit over a wide AC input voltages, from 90V_{AC} to 264V_{AC}.

SG6742 provides many protection functions. In addition to cycle-by-cycle current limiting, the internal open-loop protection circuit ensures safety should an open-loop or output short-circuit failure occur. PWM output is disabled until V_{DD} drops below the UVLO lower limit when the controller starts up again. As long as V_{DD} exceeds about 26V, the internal OVP circuit is triggered.

SG6742 is available in an 8-pin DIP or SOP package.

TYPICAL APPLICATION

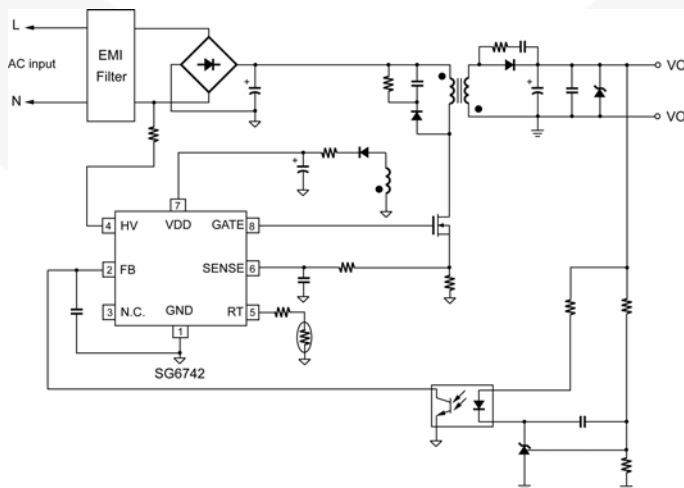

MARKING INFORMATION

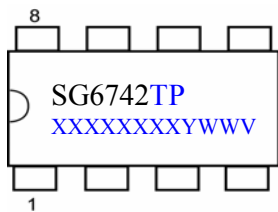

T: D = DIP, S = SOP
 P: Z =Lead Free
 Null=regular package
 XXXXXXXX: Wafer Lot
 Y: Year; WW: Week
 V: Assembly Location

PIN CONFIGURATION

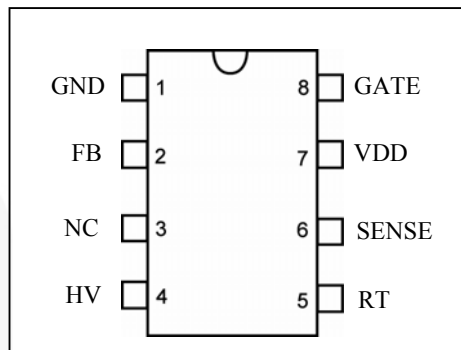

ORDERING INFORMATION

Part Number	PWM Frequency	Pb-Free	Package
SG6742SZ	65KHz		SOP-8
SG6742DZ (Preliminary)	65KHz		DIP-8

PIN DESCRIPTIONS

Pin No.	Symbol	Function	Description
1	GND	Ground	Ground.
2	FB	Feedback	The signal from the external compensation circuit is fed into this pin. The PWM duty cycle is determined in response to the signal on this pin and the current-sense signal on SENSE pin.
3	NC	NA	NC pin.
4	HV	Start-up Input	For start-up, this pin is pulled high to the line input or bulk capacitor via resistors.
5	RT	Temperature Detection	For over-temperature protection, an external NTC thermistor is connected from this pin to GND pin. The impedance of the NTC decreases at high temperatures. Once the voltage of the RT pin drops below a fixed limit, PWM output is disabled.
6	SENSE	Current Sense	Current sense. The sensed voltage is used for peak-current-mode control and cycle-by-cycle current limiting.
7	VDD	Power Supply	Power supply. The internal protection circuit disables PWM output as long as V_{DD} exceeds the OVP trigger point.
8	GATE	Driver Output	The totem-pole output driver. Soft driving waveform is implemented for improved EMI.

Highly Integrated Green-Mode PWM Controller

SG6742

BLOCK DIAGRAM

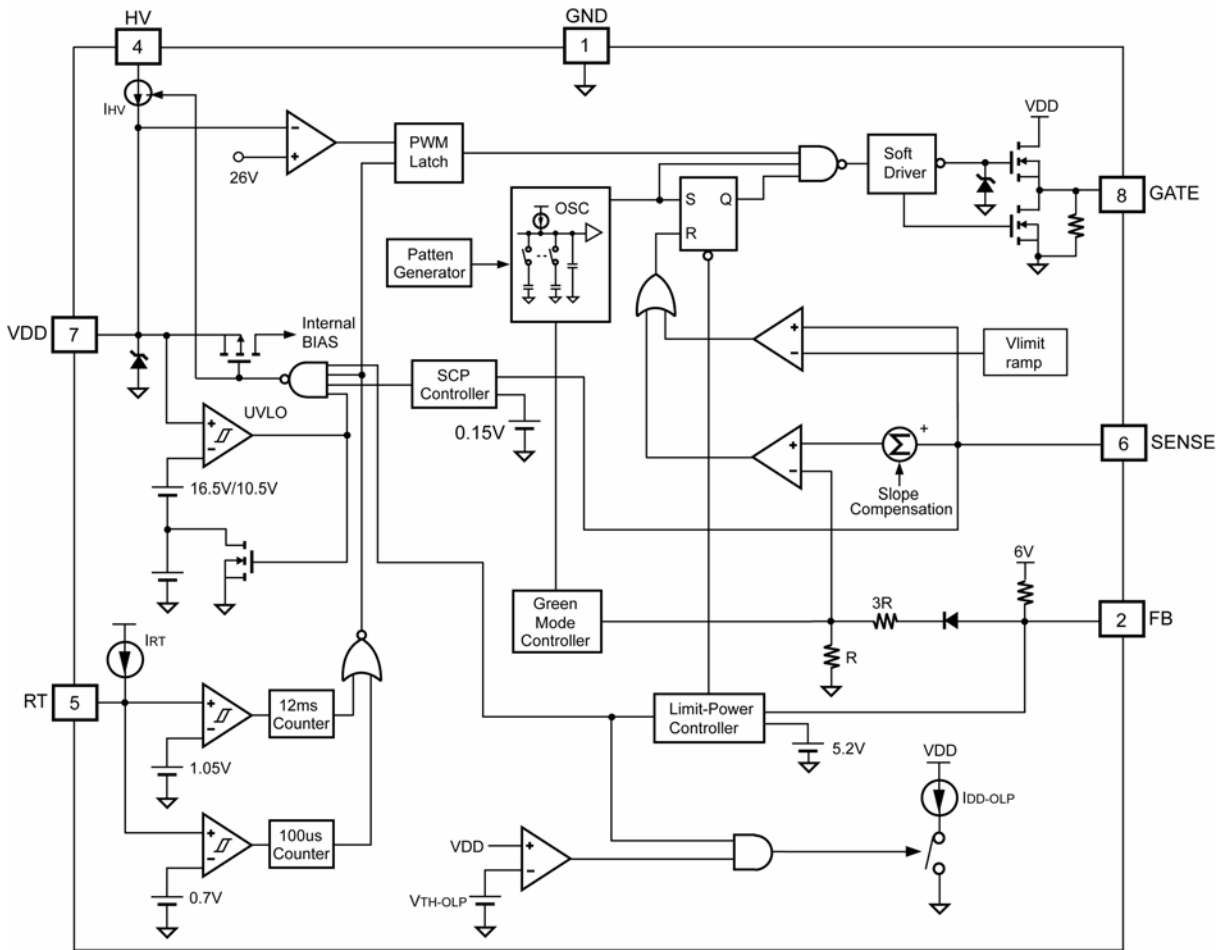

Highly Integrated Green-Mode PWM Controller
SG6742
ABSOLUTE MAXIMUM RATINGS

Symbol	Parameter	Value		Unit
V _{DD}	Supply Voltage	30		V
V _{HV}	Input Voltage to HV Pin	500		V
V _L	Input Voltage to FB, SENSE, CS Pin	-0.3 to 7.0		V
P _D	Power Dissipation T _A < 50°C	DIP	800	mW
		SOP	400	
R _{θJA}	Thermal Resistance (Junction-to-Air)	DIP	82.5	°C/W
		SOP	141.0	
T _J	Operating Junction Temperature	-40 to +125		°C
T _{STG}	Storage Temperature Range	-55 to +150		°C
T _L	Lead Temperature (Wave Soldering or Infrared, 10 Seconds)	260		°C
ESD	Electrostatic Discharge Capability, Human Body Model	All pins except HV pin	4	KV
	Electrostatic Discharge Capability, Machine Model	All pins except HV pin	400	V

* All voltage values, except differential voltages, are given with respect to the GND pin.

* Stresses beyond those listed under "absolute maximum ratings" may cause permanent damage to the device.

ELECTRICAL CHARACTERISTICS

V_{DD} = 15V; T_A = 25°C, unless otherwise noted.

V_{DD} Section

Symbol	Parameter	Test Condition	Min.	Typ.	Max.	Unit
V _{DD-OP}	Continuously Operating Voltage				22	V
V _{DD-ON}	Start Threshold Voltage		15.5	16.5	17.5	V
V _{DD-OFF}	Minimum Operating Voltage		9.5	10.5	11.5	V
I _{DD-ST}	Start-up Current	V _{DD-ON} – 0.16V			30	μA
I _{DD-OP}	Operating Supply Current	V _{DD} = 15V, GATE open		4	5	mA
I _{DD-OLP}	Internal Sink Current	V _{TH-OLP} +0.1V	50	70	90	μA
V _{TH-OLP}	I _{DD-OLP} Off Voltage		6.5	7.5	8.0	V
V _{DD-OVP}	V _{DD} Over-Voltage Protection		25	26	27	V
t _{D-VDDOVP}	V _{DD} Over-Voltage Protection Debounce Time		75	125	200	μs

HV Section

Symbol	Parameter	Test Condition	Min.	Typ.	Max.	Unit
I _{HV}	Supply Current Drawn from HV Pin	V _{AC} =90V (V _{DC} =120V) ; V _{DD} =10μF		1.2		mA
I _{HV-LC}	Leakage Current After Start-up	HV = 500V, V _{DD} = V _{DD-OFF} +1V		1	20	μA

Highly Integrated Green-Mode PWM Controller

SG6742

Oscillator Section

Symbol	Parameter	Test Condition	Min.	Typ.	Max.	Unit
F _{OSC}	Frequency in Nominal Mode	Center Frequency	62	65	68	KHz
		Hopping Range	±3.7	±4.2	±4.7	
t _{HOP}	Hopping Period			4.4		ms
F _{OSC-G}	Green-Mode Frequency		18	22	25	KHz
F _{DV}	Frequency Variation vs. V _{DD} Deviation	V _{DD} =11V to 22V			5	%
F _{DT}	Frequency Variation vs. Temp. Deviation	T _A =-20 to 85°C			5	%

* Hopping off at green-mode.

Feedback Input Section

Symbol	Parameter	Test Condition	Min.	Typ.	Max.	Unit
A _V	Input Voltage to Current-Sense Attenuation		1/4.5	1/4.0	1/3.5	V/V
Z _{FB}	Input Impedance		4		7	kΩ
V _{FB-OPEN}	Output High Voltage	FB pin open	5.5			V
V _{FB-OLP}	FB Open-Loop Trigger Level		5.0	5.2	5.4	V
t _{D-OLP}	Delay Time of FB Pin Open Loop Protection		53	56	59	ms
V _{FB-N}	Green-Mode Entry FB Voltage		1.9	2.1	2.3	V
V _{FB-G}	Green-Mode Ending FB Voltage			V _{FB-N} -0.5		V

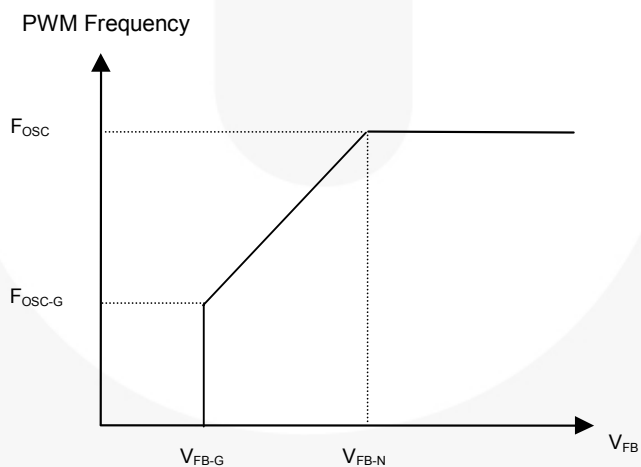

Highly Integrated Green-Mode PWM Controller

SG6742

Current-Sense Section

Symbol	Parameter	Test Condition	Min.	Typ.	Max.	Unit
Z _{SENSE}	Input Impedance			12		KΩ
V _{STHFL}	Current Limit Flatten Threshold Voltage		0.87	0.90	0.93	V
V _{STHVA}	Current Limit Valley Threshold Voltage	V _{STHFL} -V _{STHVA}	0.18	0.22	0.26	V
t _{PD}	Delay to Output			100	200	ns
t _{LEB}	Leading-Edge Blanking Time		275	350	425	ns
V _{S-SCP}	Threshold Voltage for SENSE Short-circuit Protection		0.10	0.15	0.20	V
t _{D-SSCP}	Delay Time for SENSE Short-circuit Protection	V _{SENSE} < 0.15V	100	150	200	μs

GATE Section

Symbol	Parameter	Test Condition	Min.	Typ.	Max.	Unit
DCY _{MAX}	Maximum Duty Cycle		60	65	70	%
V _{GATE-L}	Gate Low Voltage	V _{DD} =15V, I _O =50mA			1.5	V
V _{GATE-H}	Gate High Voltage	V _{DD} =12V, I _O =50mA	8			V
t _r	Gate Rising Time	V _{DD} =15V, C _L =1nF	150	250	350	ns
t _f	Gate Falling Time	V _{DD} =15V, C _L =1nF	30	50	90	ns
I _{GATE-SOURCE}	Gate Source Current	V _{DD} =15V, GATE=6V	250			mA
V _{GATE-CLAMP}	Gate Output Clamping Voltage	V _{DD} =22V			18	V

RT Section

Symbol	Parameter	Test Condition	Min.	Typ.	Max.	Unit
I _{RT}	Output Current from the RT Pin		92	100	108	μA
V _{RTTH1}	Over-Temperature Protection Threshold Voltage	0.7V < V _{RT} < 1.05V, after 12ms latch off	1.015	1.050	1.085	V
V _{RTTH2}	Over-Temperature Protection Threshold Voltage	V _{RT} < 0.7V, after 100μs latch off	0.65	0.70	0.75	V
t _{D-OTP1}	Over-Temperature Latch-off Debounce	V _{RTTH2} < V _{RT} < V _{RTTH1}	8	12	16	ms
t _{D-OTP2}	Over-Temperature Latch-off Debounce	V _{RT} < V _{RTTH2}	60	100	140	μs

Over Temperature Protection (OTP)

Symbol	Parameter	Test Condition	Min.	Typ.	Max.	Unit
T _{OTP}	Protection Junction Temperature*			135		°C
T _{Restart}	Restart Junction Temperature**			T _{OTP} -25		°C

* When activated, the output is disabled and the latch is turned off.

** This is the threshold temperature for enabling the output again and resetting the latch after over-temperature protection has been activated.

Highly Integrated Green-Mode PWM Controller

SG6742

TYPICAL CHARACTERISTICS

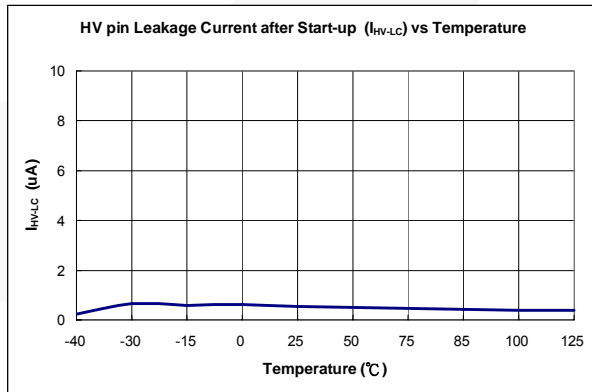
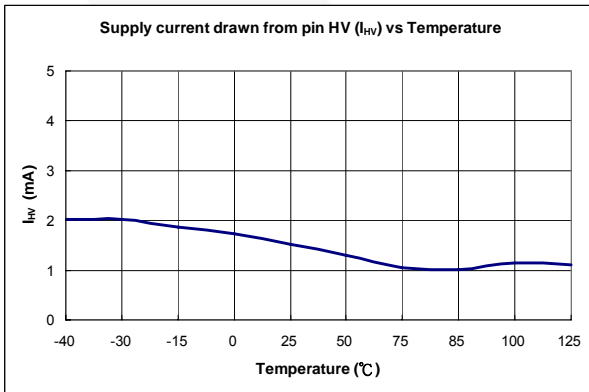
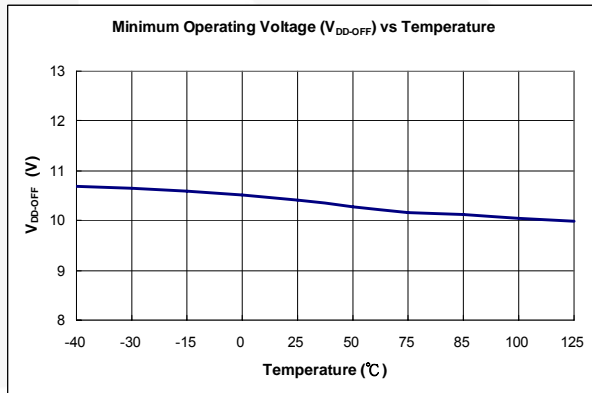
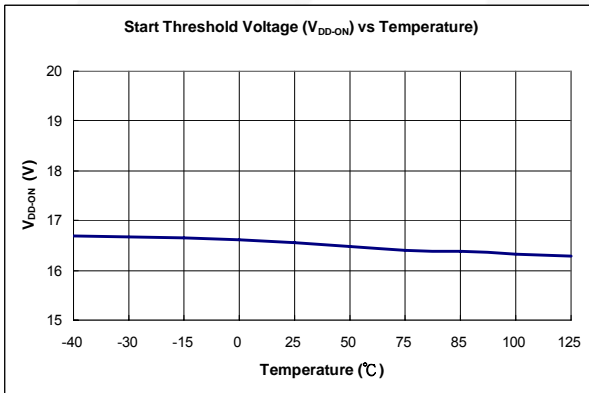
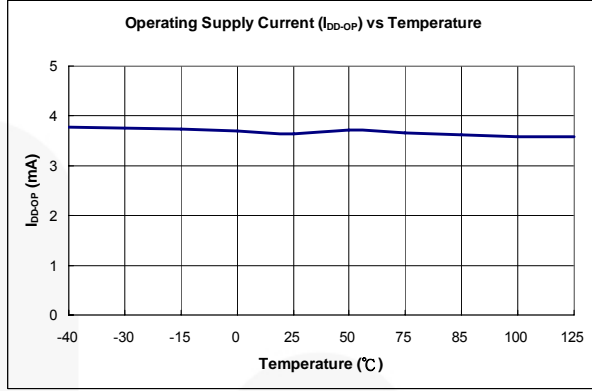
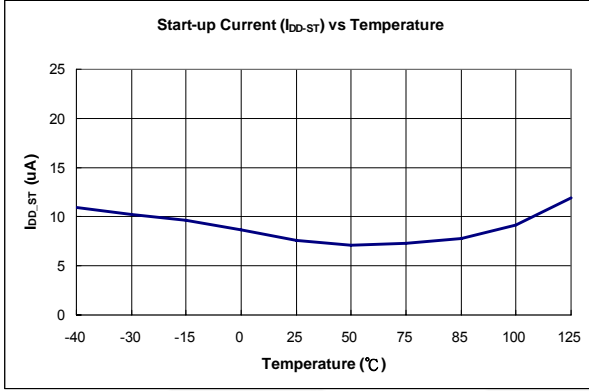

Highly Integrated Green-Mode PWM Controller

SG6742

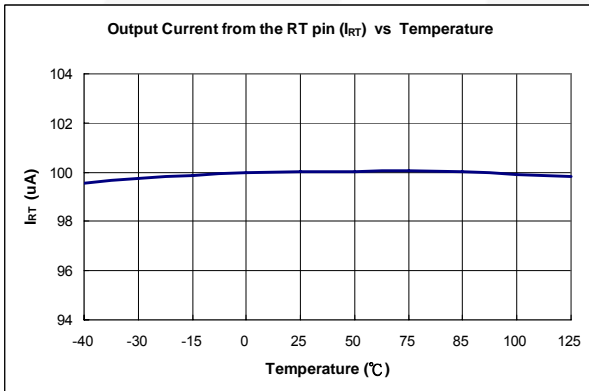
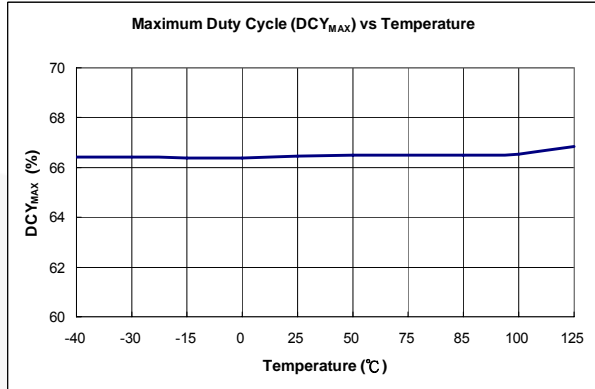
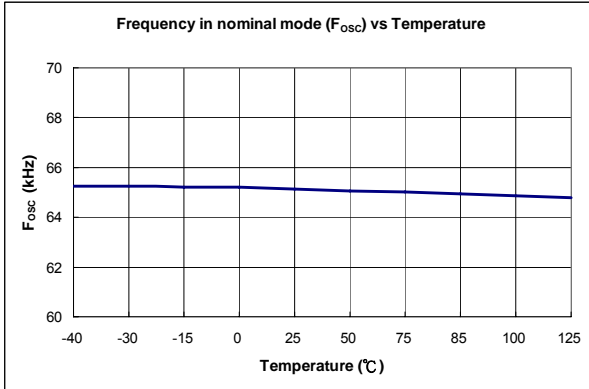

OPERATION DESCRIPTION

Start-up Current

For start-up, the HV pin is connected to the line input or bulk capacitor through an external diode and resistor R_{HV} , which are recommended as 1N4007 and 100K Ω . Typical start-up current drawn from the HV pin is 1.2mA and it charges the hold-up capacitor through the diode and resistor. When the V_{DD} capacitor level reaches V_{DD-ON} , the start-up current switches off. At this moment, the V_{DD} capacitor only supplies the SG6742 to keep the V_{DD} before the auxiliary winding of the main transformer to carry on provide the operating current.

Operating Current

Operating current is around 4mA. The low operating current enables better efficiency and reduces the requirement of V_{DD} hold-up capacitance.

Green-Mode Operation

The patented green-mode function provides an off-time modulation to reduce the switching frequency in light-load and no-load conditions. The on-time is limited for better abnormal or brownout protection. V_{FB} , which is derived from the voltage feedback loop, is taken as the reference. Once V_{FB} is lower than the threshold voltage, switching frequency is continuously decreased to the minimum green mode frequency, around 22KHz.

Current Sensing / PWM Current Limiting

Peak-current-mode control is utilized to regulate output voltage and provide pulse-by-pulse current limiting. The switch current is detected by a sense resistor into the SENSE pin. The PWM duty cycle is determined by this current sense signal and V_{FB} , the feedback voltage. When the voltage on the SENSE pin reaches around $V_{COMP} = (V_{FB}-1.2)/4$, a switch cycle is terminated immediately. V_{COMP} is internally clamped to a variable voltage around 0.85V for output power limit.

Leading-Edge Blanking

Each time the power MOSFET is switched on, a turn-on spike occurs on the sense-resistor. To avoid premature termination of the switching pulse, a leading-edge blanking time is built in. During this blanking period, the current-limit comparator is disabled and it cannot switch off the gate driver.

Under-Voltage Lockout (UVLO)

The turn-on and turn-off threshold are fixed internally at 16.5V/10.5V. During start-up, the hold-up capacitor must be charged to 16.5V through the start-up resistor so that IC is enabled. The hold-up capacitor continues to supply V_{DD} before the energy can be delivered from auxiliary winding of the main transformer. V_{DD} must not drop below 10.5V during this start-up process. This UVLO hysteresis window ensures that hold-up capacitor is adequate to supply V_{DD} during start-up.

Gate Output / Soft Driving

The SG6742 BiCMOS output stage is a fast totem pole gate driver. Cross conduction is avoided to minimize heat dissipation, increases efficiency, and enhances reliability. The output driver is clamped by an internal 18V Zener diode to protect power MOSFET transistors against undesirable gate over voltage. A soft driving waveform is implemented to minimize EMI.

Built-in Slope Compensation

The sensed voltage across the current-sense resistor is used for peak-current-mode control and pulse-by-pulse current limiting. Built-in slope compensation improves stability or prevents sub-harmonic oscillation. SG6742 inserts a synchronized positive-going ramp at every switching cycle.

Constant Output Power Limit

When the SENSE voltage, across the sense resistor R_s , reaches the threshold voltage, around 0.9V, the output GATE drive is turned off after a small delay, t_{PD} . This delay introduces additional current, proportional to $t_{PD} \cdot V_{IN} / L_p$. Since the delay is nearly constant, regardless of the input voltage V_{IN} , higher input voltage results in a larger additional current and the output power limit is higher than under low input line voltage. To compensate this variation for wide AC input range, a sawtooth power-limiter is designed to solve the unequal power-limit problem. The power limiter is designed as a positive ramp signal and is fed to the inverting input of the OCP comparator. This results in a lower current limit at high-line inputs than at low-line inputs.

Highly Integrated Green-Mode PWM Controller

SG6742

V_{DD} Over-Voltage Protection

V_{DD} over-voltage protection has been built in to prevent damage due to abnormal conditions. Once the V_{DD} voltage is over the over-voltage protection voltage (V_{DD-OVP}) and lasts for t_{D-VDDOVP}, the PWM pulses are disabled until the V_{DD} voltage drops below the UVLO, then start-up again. Over-voltage conditions are usually caused by open feedback loops.

Thermal Protection

An NTC thermistor R_{NTC} in series with a resistor R_A can be connected from pin RT to ground. A constant current I_{RT} is output from pin RT. The voltage on RT pin can be expressed as V_{RT} = I_{RT} × (R_{NTC} + R_A), in which I_{RT} = 2 × (1.3V / R_I). At high ambient temperature, R_{NTC} is smaller, such that V_{RT} decreases. When V_{RT} is less than 1.05V (V_{RTTH1}), the PWM is turned off after 12ms (t_{D-OTP1}). If V_{RT} is less than 0.7V (V_{RTTH2}), PWM should be turned off immediately after 100μs (t_{D-OTP2}).

Limited Power Control

The FB voltage increases every time the output of the power supply is shorted or over-loaded. If the FB voltage remains higher than a built-in threshold for longer than t_{D-OLP}, PWM output is turned off. As PWM output is turned off, the supply voltage V_{DD} begins decreasing.

When V_{DD} goes below the turn-off threshold (eg, 10.5V) the controller is totally shut down. V_{DD} is charged up to the turn-on threshold voltage of 16V through the start-up resistor until PWM output is restarted. This protection feature is activated as long as the over-loading condition persists. This prevents the power supply from overheating due to over loading conditions.

Noise Immunity

Noise on the current sense or control signal may cause significant pulse width jitter, particularly in continuous-conduction mode. Slope compensation helps alleviate this problem. Good placement and layout practices should be followed. Avoiding long PCB traces and component leads, locating compensation and filter components near the SG6742, and increasing the power MOS gate resistance improves performance.

Highly Integrated Green-Mode PWM Controller

SG6742

REFERENCE CIRCUIT (12V/5A)

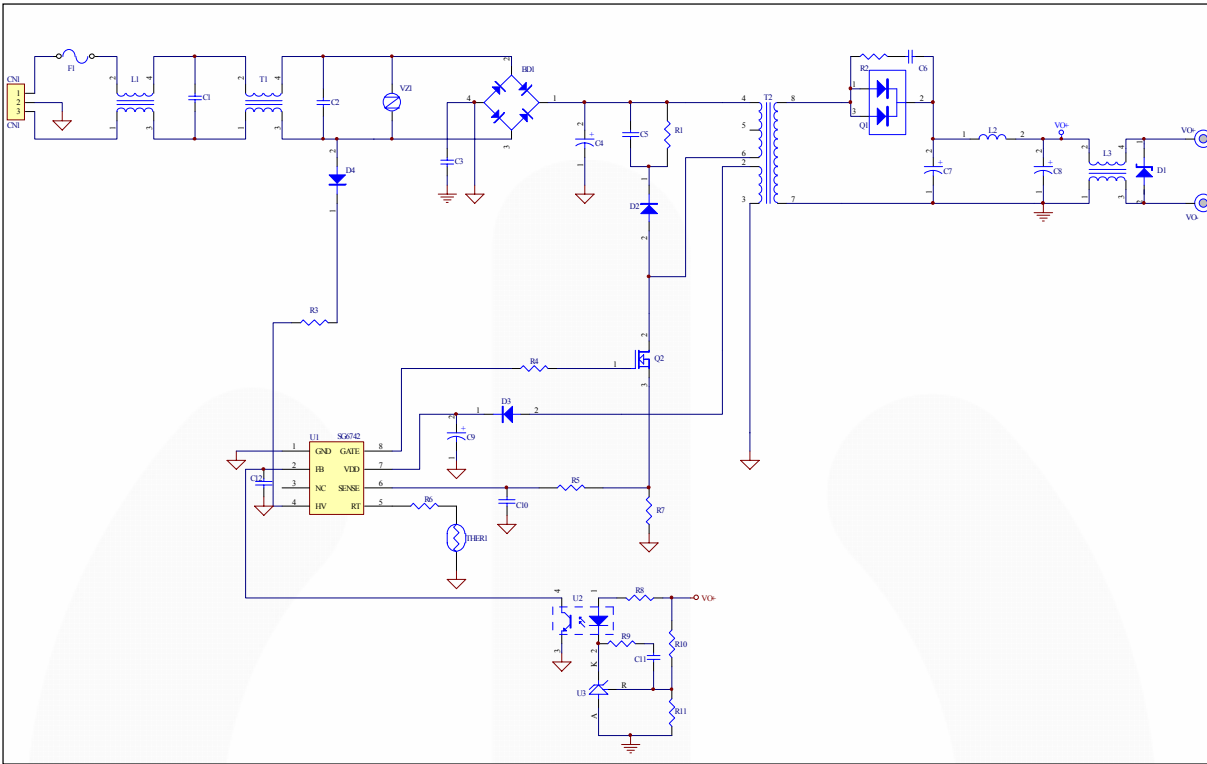

BOM

Reference	Component	Reference	Component
BD1	BD 4A/600V	Q1	STP20-100CT
C1	XC 0.68μF/300V	Q2	MOS 7A/600V
C2	XC 0.1μF/300V	R1	R 100Kohm 1/2W
C3	YC 222pF/Y1	R2	R 47ohm 1/4W
C4	EC 120μF/400V	R3	R 100Kohm 1/2W
C5	CC 0.01μF/500V	R4	R 20ohm 1/8W
C6	CC 102pF/100V	R5	R 100ohm 1/8W
C7	EC 1000μF/25V	R6	R 4.7Kohm 1/8W
C8	EC 470μF/25V	R7	R 0.3ohm 2W
C9	EC 22μF/50V	R8	R 680ohm 1/8W
C10	CC 470pF/50V	R9	R 4.7Kohm 1/8W
C11	CC 222pF/50V	R10	R 150Kohm 1/8W
C12	CC 103pF/50V	R11	R 39Kohm 1/8W
D1	Zener Diode 15V 1/2W (option)	THER1	Thermistor TTC104
D2	BYV95C	T1	10mH
D3	FR103	T2	600μH(PQ2620)
D4	1N4007	U1	IC SG6742
F1	FUSE 4A/250V	U2	IC PC817
L1	Inductor (900μH)	U3	IC TL431
L2	Inductor (2μH)	VZ1	VZ 9G
L3	Inductor (900μH)		

PACKAGE INFORMATION

8PINS-DIP(D)

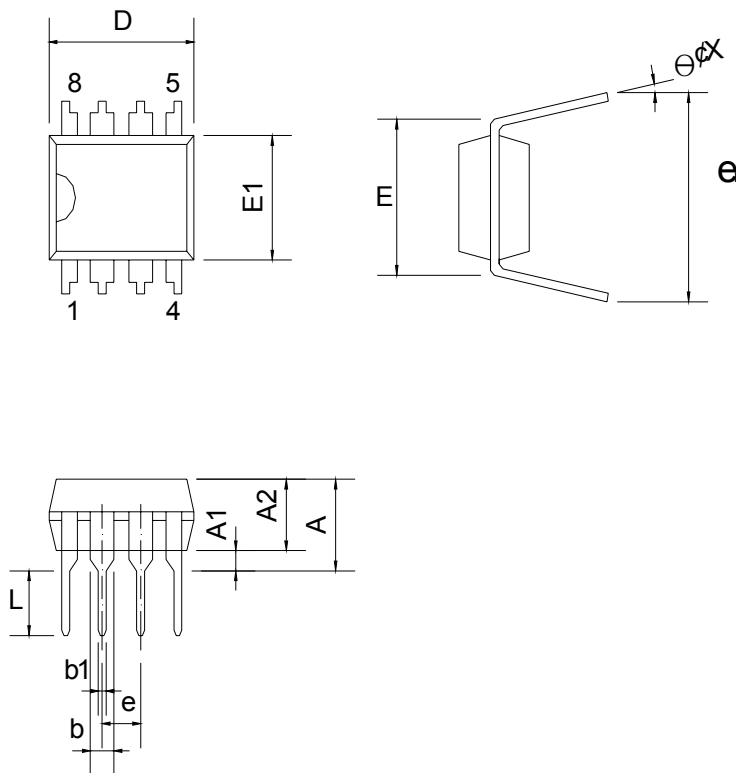

Dimensions

Symbol	Millimeters			Inches		
	Min.	Typ.	Max.	Min.	Typ.	Max.
A			5.334			0.210
A1	0.381			0.015		
A2	3.175	3.302	3.429	0.125	0.130	0.135
b		1.524			0.060	
b1		0.457			0.018	
D	9.017	9.271	10.160	0.355	0.365	0.400
E		7.620			0.300	
E1	6.223	6.350	6.477	0.245	0.250	0.255
e		2.540			0.100	
L	2.921	3.302	3.810	0.115	0.130	0.150
eB	8.509	9.017	9.525	0.335	0.355	0.375
θ°	0°	7°	15°	0°	7°	15°

8PINS-SOP(S)

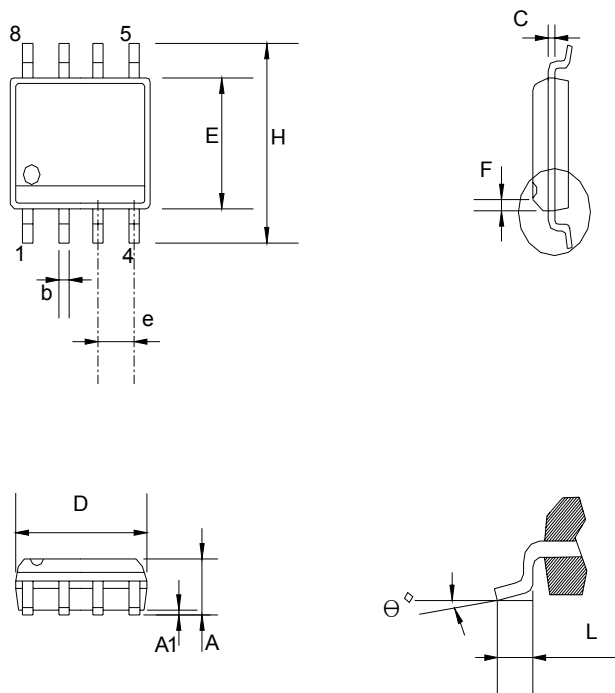

Dimensions

Symbol	Millimeter			Inch		
	Min.	Typ.	Max.	Min.	Typ.	Max.
A	1.346		1.752	0.053		0.069
A1	0.101		0.254	0.004		0.010
b		0.406			0.016	
c		0.203			0.008	
D	4.648		4.978	0.183		0.196
E	3.810		3.987	0.150		0.157
e	1.016	1.270	1.524	0.040	0.050	0.060
F		0.381X45°			0.015X45°	
H	5.791		6.197	0.228		0.244
L	0.406		1.270	0.016		0.050
θ°	0°		8°	0°		8°

Highly Integrated Green-Mode PWM Controller

SG6742



TRADEMARKS

The following are registered and unregistered trademarks and service marks Fairchild Semiconductor owns or is authorized to use and is not intended to be an exhaustive list of all such trademarks.

- | | | | |
|--------------------------------------|--|--|----------------------------------|
| ACEx [®] | Green FPS [™] | Power247 [®] | SuperSOT [™] -8 |
| Build it Now [™] | Green FPS [™] e-Series [™] | POWEREDGE [®] | SyncFET [™] |
| CorePLUS [™] | GTO [™] | Power-SPM [™] | The Power Franchise [®] |
| CROSSVOLT [™] | i-Lo [™] | PowerTrench [®] | the power franchise |
| CTL [™] | IntelliMAX [™] | Programmable Active Droop [™] | TinyBoost [™] |
| Current Transfer Logic [™] | ISOPLANAR [™] | QFET [®] | TinyBuck [™] |
| EcoSPARK [®] | MegaBuck [™] | QS [™] | TinyLogic [®] |
| F [®] | MICROCOUPLER [™] | QT Optoelectronics [™] | TINYOPTO [™] |
| Fairchild [®] | MicroFET [™] | Quiet Series [™] | TinyPower [™] |
| Fairchild Semiconductor [®] | MicroPak [™] | RapidConfigure [™] | TinyPWM [™] |
| FACT Quiet Series [™] | MillerDrive [™] | SMART START [™] | TinyWire [™] |
| FACT [®] | Motion-SPM [™] | SPM [®] | μSerDes [™] |
| FAST [®] | OPTOLOGIC [®] | STEALTH [™] | UHC [®] |
| FastvCore [™] | OPTOPLANAR [®] | SuperFET [™] | UniFET [™] |
| FPST [™] |  [®] | SuperSOT [™] -3 | VCX [™] |
| FRFET [®] | PDP-SPM [™] | SuperSOT [™] -6 | |
| Global Power Resource SM | Power220 [®] | | |

DISCLAIMER

FAIRCHILD SEMICONDUCTOR RESERVES THE RIGHT TO MAKE CHANGES WITHOUT FURTHER NOTICE TO ANY PRODUCTS HEREIN TO IMPROVE RELIABILITY, FUNCTION, OR DESIGN. FAIRCHILD DOES NOT ASSUME ANY LIABILITY ARISING OUT OF THE APPLICATION OR USE OF ANY PRODUCT OR CIRCUIT DESCRIBED HEREIN; NEITHER DOES IT CONVEY ANY LICENSE UNDER ITS PATENT RIGHTS, NOR THE RIGHTS OF OTHERS. THESE SPECIFICATIONS DO NOT EXPAND THE TERMS OF FAIRCHILD'S WORLDWIDE TERMS AND CONDITIONS, SPECIFICALLY THE WARRANTY THEREIN, WHICH COVERS THESE PRODUCTS.

LIFE SUPPORT POLICY

FAIRCHILD'S PRODUCTS ARE NOT AUTHORIZED FOR USE AS CRITICAL COMPONENTS IN LIFE SUPPORT DEVICES OR SYSTEMS WITHOUT THE EXPRESS WRITTEN APPROVAL OF FAIRCHILD SEMICONDUCTOR CORPORATION.

As used herein:

1. Life support devices or systems are devices or systems which, (a) are intended for surgical implant into the body or (b) support or sustain life, and (c) whose failure to perform when properly used in accordance with instructions for use provided in the labeling, can be reasonably expected to result in a significant injury of the user.
2. A critical component in any component of a life support, device, or system whose failure to perform can be reasonably expected to cause the failure of the life support device or system, or to affect its safety or effectiveness.

PRODUCT STATUS DEFINITIONS

Definition of Terms

Datasheet Identification	Product Status	Definition
Advance Information	Formative or In Design	This datasheet contains the design specifications for product development. Specifications may change in any manner without notice.
Preliminary	First Production	This datasheet contains preliminary data; supplementary data will be published at a later date. Fairchild Semiconductor reserves the right to make changes at any time without notice to improve design.
No Identification Needed	Full Production	This datasheet contains final specifications. Fairchild Semiconductor reserves the right to make changes at any time without notice to improve design.
Obsolete	Not In Production	This datasheet contains specifications on a product that has been discontinued by Fairchild Semiconductor. The datasheet is printed for reference information only.

Rev. I31